**Pepper (*Piper nigrum* L.), whole or
ground — Specification —**

**Part 2:
White pepper**

*Poivre (Piper nigrum L.), entier ou en poudre — Spécifications —
Partie 2: Poivre blanc*

iTeh STANDARD PREVIEW
(standards.iteh.ai)

ISO 959-2:1998

<https://standards.iteh.ai/catalog/standards/sist/d943c959-5e5b-437e-be1d-dc97df074de7/iso-959-2-1998>



Foreword

ISO (the International Organization for Standardization) is a worldwide federation of national standards bodies (ISO member bodies). The work of preparing International Standards is normally carried out through ISO technical committees. Each member body interested in a subject for which a technical committee has been established has the right to be represented on that committee. International organizations, governmental and non-governmental, in liaison with ISO, also take part in the work. ISO collaborates closely with the International Electrotechnical Commission (IEC) on all matters of electrotechnical standardization.

International Standards are drafted in accordance with the rules given in the ISO/IEC Directives, Part 3.

Draft International Standards adopted by the technical committees are circulated to the member bodies for voting. Publication as an International Standard requires approval by at least 75 % of the member bodies casting a vote.

International Standard ISO 959-2 was prepared by Technical Committee TC 34, *Agricultural food products*, Subcommittee SC 7, *Spices and condiments*.

This second edition cancels and replaces the first edition (ISO 959-2:1989), which has been technically revised.

ISO 959 consists of the following parts, under the general title *Pepper (Piper nigrum L.), whole or ground — Specification*:

— Part 1: *Black pepper*

— Part 2: *White pepper*

iteh STANDARD PREVIEW
(standards.iteh.ai)
ISO 959-2:1998
<https://standards.iteh.ai/catalog/standards/sist/d943c959-5e5b-437e-be1d-409a97407289/iso-959-2-1998>

Annex A forms an integral part of this part of ISO 959; Annex B is for information only.

© ISO 1998

All rights reserved. Unless otherwise specified, no part of this publication may be reproduced or utilized in any form or by any means, electronic or mechanical, including photocopying and microfilm, without permission in writing from the publisher.

International Organization for Standardization
Case postale 56 • CH-1211 Genève 20 • Switzerland
Internet central@iso.ch
X.400 c=ch; a=400net; p=iso; o=isocs; s=central

Printed in Switzerland

Pepper (*Piper nigrum* L.), whole or ground — Specification —

Part 2: White pepper

1 Scope

This part of ISO 959 specifies requirements for white pepper (*Piper nigrum* L.) (see ISO 676), whole or ground, at the following commercial stages:

- a) semi-processed (SP);
- b) processed (P).

When the term "white pepper" is used alone, it means that the specification applies to both types described, without distinction.

This part of ISO 959 is not applicable to white pepper categories called "light".

NOTE Specifications for white pepper are given in ISO 959-1.

Recommendations relating to storage and transport conditions are given in annex B.

<https://standards.iteh.ai/catalog/standards/sist/d943c959-5e5b-437e-be1d-dc97df074de7/iso-959-2-1998>

2 Normative references

The following standards contain provisions which, through reference in this text, constitute provisions of this part of ISO 959. At the time of publication, the editions indicated were valid. All standards are subject to revision, and parties to agreements based on this part of ISO 959 are encouraged to investigate the possibility of applying the most recent editions of the standards indicated below. Members of IEC and ISO maintain registers of currently valid International Standards.

- ISO 676:1995, *Spices and condiments — Nomenclature*
- ISO 927:1982, *Spices and condiments — Determination of extraneous matter content.*
- ISO 928:1997, *Spices and condiments — Determination of total ash.*
- ISO 930:1997, *Spices and condiments — Determination of acid-insoluble ash.*
- ISO 939:1980, *Spices and condiments — Determination of moisture content — Entrainment method.*
- ISO 948:1980, *Spices and condiments — Sampling.*
- ISO 1108:1992, *Spices and condiments — Determination of non-volatile ether extract.*
- ISO 1208:1982, *Spices and condiments — Determination of filth.*
- ISO 5498:1981, *Agricultural food products — Determination of crude fibre content — General method.*

ISO 5564:1982, *White pepper and white pepper, whole or ground — Determination of piperine content — Spectrophotometric method.*

ISO 6571:1984, *Spices, condiments and herbs — Determination of volatile oil content.*

3 Definitions

For the purposes of this part of ISO 959, the following definitions apply

3.1

black pepper

dried berry of *Piper nigrum* L., having an unbroken pericarp

3.2

white pepper

berry of *Piper nigrum* L., from which the outer pericarp has been removed
(See 4.1.)

3.3

white pepper, semi-processed (SP)

pepper that has undergone a partial treatment by the producing country before being exported, and that conforms to the requirements of this part of ISO 959

3.4

white pepper, processed (P)

pepper that has been processed (cleaning, drying, preparation, grading, etc.) by the producing country before being exported, and that conforms to the requirements of this part of ISO 959

3.5

white pepper, ground

pepper obtained by grinding white pepper berries without adding any foreign matter to the pepper (e.g. whitening agents), and that conforms to the requirements of this part of ISO 959

3.6

black berry

berry of dark colour, generally consisting of a black pepper berry whose pericarp has not been fully removed

3.7

broken berry

berry that has been separated into two or more pieces

3.8

extraneous matter

all materials other than white pepper berries, irrespective of whether they are of vegetable (e.g. stems and leaves) or mineral (e.g. sand) origin

NOTE Black and broken berries are not considered as extraneous matter.

4 Description

4.1 Whole white pepper is obtained in two ways, as follows:

- a) from black pepper using the whole dry berry of *Piper nigrum* L., generally picked before complete ripening, and removing the outer pericarp, with or without preliminary soaking in water; if necessary, drying is carried out afterwards;
- b) from the whole ripe berry of *Piper nigrum* L., removing the outer pericarp by the same procedure as described above.

Berries of white pepper are generally spherical in shape, of diameter 3 mm to 6 mm, having a smooth surface, and are slightly flattened at one pole and have a small protuberance at the other.

Berries generally have vertical scores going from one pole to the other, of a slightly darker colour. The colour of white pepper varies from matt brownish grey to pale ivory white.

4.2 Ground white pepper is obtained by grinding white pepper berries, without adding any foreign matter to the pepper.

5 Requirements

5.1 Odour and flavour

When ground, the odour and flavour shall be characteristic of white pepper, slightly sharp and very aromatic. The product shall be free from foreign odours and flavours.

NOTE The appearance of berries has no direct relation to their flavour. Smaller berries can be more aromatic than berries of larger size or of better appearance.

ITeH STANDARD PREVIEW
(standards.iteh.ai)

5.2 Freedom from mould, insects, etc. ISO 959-2:1998

White pepper shall be free from mould growth and living insects, and practically free from dead insects, insect fragments and rodent contamination visible to the naked eye (corrected, if necessary, for abnormal vision) or with such magnification as may be necessary in any particular case. If the magnification exceeds x10, this fact shall be mentioned in the test report.

In the case of ground white pepper, impurities shall be determined according to the method given in ISO 1208.

5.3 Physical characteristics

Whole white pepper shall meet the requirements specified in table 1.

5.4 Chemical characteristics

The white pepper shall meet the requirements specified in table 2 when tested by the specified method.

6 Sampling

White pepper shall be sampled using the method specified in ISO 948.

Samples of whole white pepper shall be ground so that all material passes through a sieve with apertures of size 1 mm. The material thus obtained shall be used for determining the characteristics given in table 2.

7 Test methods

Samples of white pepper shall be analysed to ensure conformity with the requirements of this part of ISO 959 by following the methods specified in tables 1 and 2.

Table 1 — Physical characteristics of whole white pepper

Characteristics	Requirements		Reference test method
	Pepper SP	Pepper P	
Extraneous matter, % (<i>m/m</i>) max.	1,0	0,8	ISO 927
Broken berries, % (<i>m/m</i>) max.	4,0	3,0	Physical separation and weighing
Black berries, % (<i>m/m</i>) max.	15 ^a)	10 ^a)	Physical separation and weighing
Bulk density, g/l, min.	600	600	Annex A

a) These values do not apply to "Samarinda" pepper, which always contains 20 % black berries.

Table 2 — Chemical requirements of white pepper, whole or ground

Characteristics	Requirements		Reference test method
	Pepper S or SP	Ground pepper	
Moisture content, % (<i>m/m</i>) max.	14,0	14,0	ISO 939
Total ash, % (<i>m/m</i>) max., on dry basis	3,5	3,5	ISO 928
Volatile oils, % (ml/100 g) min., on dry basis	1,0	0,7 ^a)	ISO 6571
Non-volatile ether extract (<i>m/m</i>) % min., on dry basis	6,5	6,5	ISO 1108
Piperine content, % (<i>m/m</i>) min., on dry basis	4,0	4,0	ISO 5564
Acid-insoluble ash, % (<i>m/m</i>) max., on dry basis	—	0,3	ISO 930
Crude fibre, % (<i>m/m</i>) max., on dry basis	—	6,5	ISO 5498

a) The volatile oil content should be determined immediately after grinding.

8 Packing and marking

8.1 Packing

Whole white pepper and ground white pepper shall be packed in clean, sound, dry packages, made of a material which does not affect the product but which protects it from the ingress of moisture or loss of volatile matter.

The packaging shall also comply with any national legislation relating to environmental protection.

8.2 Marking

The following particulars shall be marked on each package or on a label attached to the package:

- a) name of the product and the tradename, if any;
- b) name and address of the manufacturer or packer, or trademark;
- c) code or batch number;
- d) net mass;
- e) commercial stage (SP or P);
- f) producing country;
- g) destination, i.e. the name of port or town;
- h) any other information requested by the buyer, such as the year of harvest and the date of packaging;
- i) reference to this part of ISO 959-2:1998.

iTeh STANDARD PREVIEW
(standards.iteh.ai)

[ISO 959-2:1998](https://standards.iteh.ai/catalog/standards/sist/d943c959-5e5b-437e-be1d-dc97df074de7/iso-959-2-1998)

<https://standards.iteh.ai/catalog/standards/sist/d943c959-5e5b-437e-be1d-dc97df074de7/iso-959-2-1998>

Annex A (normative)

Whole white pepper: Determination of apparent bulk density

A.1 Scope

This annex specifies a method for the determination of the apparent bulk density of whole white pepper.

A.2 Principle

Weighing a volume, exactly measured, of 1 litre of pepper.

A.3 Apparatus

A.3.1 Apparatus for measuring bulk density, consisting of

- **cylinder**, of capacity 1 litre, or a cylinder of greater capacity but equipped with apparatus allowing levelling of the product to the 1 level;
- **hopper**, of capacity greater than 1 litre and equipped with a gate;
- **device**, for fixing the hopper above the cylinder at a certain distance, to allow free fall of the product into the cylinder from a constant height.

Figure A.1 shows an example of such an apparatus.

NOTE This is the apparatus applicable to the reference method. However, for routine control and when the apparatus described is not available, it is possible to use a cylinder of 1 litre capacity and a funnel.

A.3.2 Balance

A special balance allowing the cylinder to be hooked to one side of the beam and equipped on the other side with a suitable plate serving as tare.

A.4 Procedure

A.4.1 Determination

Weigh the empty cylinder, if necessary.

Place the cylinder on a horizontal plane and set the hopper on it with a fixing device.

Pour the pepper into the hopper until it is filled. Open the gate and allow the pepper berries to flow freely into the cylinder until the level slightly exceeds the upper level or the 1 litre level, according to the apparatus used.

Level the pepper, according to the case, to the upper level of the cylinder with a ruler, or to the 1 litre level with a suitable device with which the cylinder is equipped. In the latter case, remove the excess berries.

Dimensions in millimetres

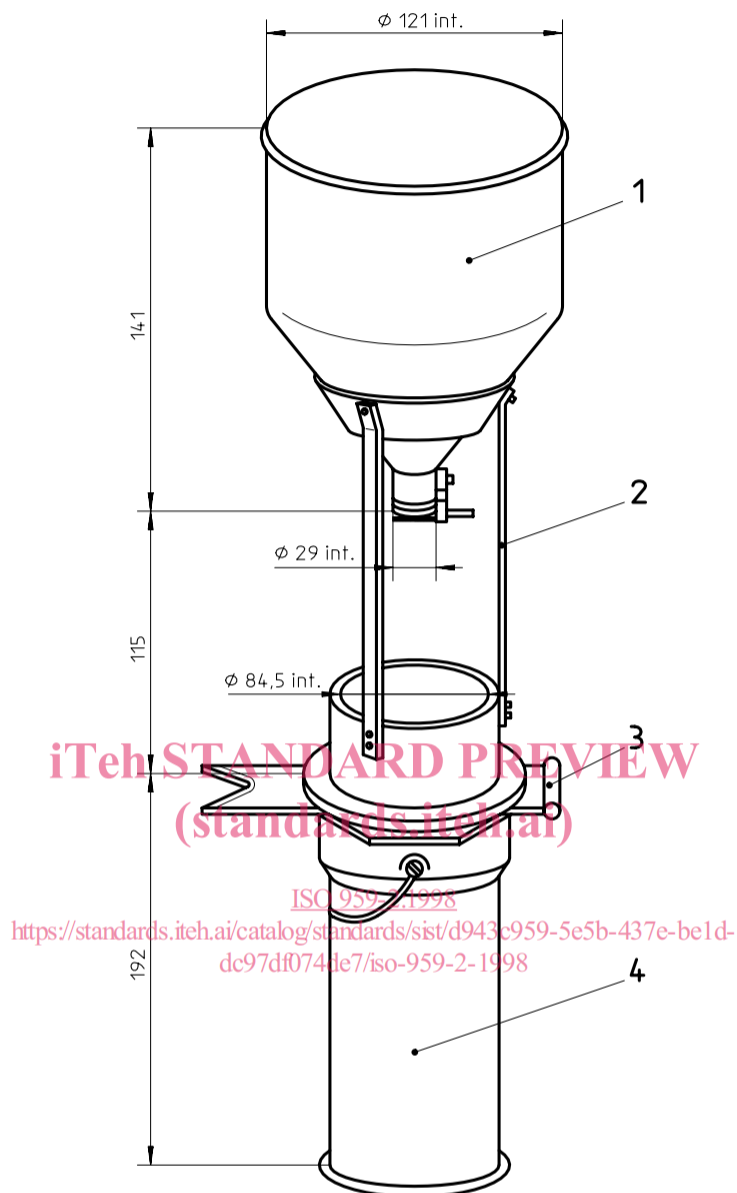
**Key**

- 1 Filling hopper
- 2 Funnel supports
- 3 Cut-off blade
- 4 Measuring container, capacity 1 litre

NOTE Figure A.1 gives the dimensions of the apparatus of 1 litre capacity. If it is required to carry out the determination with a sample reduced to half, an apparatus the dimensions of which are also reduced in the same proportions can be used, but this is solely under the responsibility of the operator. **Only the 1 litre method is the reference method.**

Figure A.1 — Nilema-litre apparatus